

The movable pig abattoir equipment quotation



Qingdao Empire Machinery Co., Ltd (EME)

Address: #50 Suzhou Road Jiaozhou Qingdao City Shandong Province, China

Tel: +86 151 54298833/+86 158 70998833 (WhatsApp)

Website: www.eme-abattoir.com

Email: alex@eme-abattoir.com/sales01@eme-abattoir.com

I、 The pig abattoir project proposal brief introduce

1.1 Pig abattoir project main data

- | | | |
|---|-------|------------------------|
| 1). Design Capacity | ----- | 10-50Per shift |
| 2). Pig Abattoir Plant Out Size (LXWXH) | ----- | 12000 X 2300 X 2700 MM |
| 3). Deliver Period In China | ----- | 20-30Days |
| (The delivery as per buyer' s down-payment value have been received in China) | | |
| 4). Installation and Debugging Technicians | ----- | 1Person |
| 5). Installation and Debugging Period | ----- | 10Days |
| 6). Voltage Rating | ----- | 380V / 3P / 50HZ |
| 7). Electric Consumption | ----- | 20Kw/Hour |
| 8). Water Consumption | ----- | 3-5Ton/Shift |
| 9). Slaughterhouse Worker | ----- | 5-10Person/Shift |
| 10). Pig Carcass Treatment Way | ----- | De-Hair Only |
| 11). Scalding Temperature | ----- | 58-62°C |
| 12). Scalding Time | ----- | 3-4Minutes |

1.2 Quality standard: the equipment are in compliance with the related ISO9001: 2008 standard

1.3 Design religion: Compliance international standard slaughtering tradition

1.4 Deliver Items: FOB

✓ Loading port: Qingdao port of China

1.5 Transportation way: Complete pig abattoir equipment need one piece 40HQ containers for transportation by sea

1.6 Packaging standard: original factory packaging loading in container

1.7 Payment way: the total invoice value will be payment as two time, the detail as following:

✓ The down-payment 40% of total invoice value will be payment within 10days from sale contract signature date through telegraphic transfer

✓ The rest 60% of total invoice value will be payment through telegraphic transfer before all equipment deliver from Qingdao port of China, meanwhile the seller party will invite buyer send one representative come to factory for equipment checking before loading into container for shipment
Quality Guarantee: The quality guarantee period of all equipment is 12 months since the date when the installation and debug have been complete, the equipment are made available to buyer and signature is made on the Buyer' s Completed Bill.

1.8 Quality guarantee: the quality guarantee period of all equipment are 12 months since the date when the installation and debug have been complete, the equipment are made available to buyer and signature is made on the buyer' s completed bill.

1.9 Machinery maintaining: The seller will appoint one well skilled technician go to maintain the equipment for five workdays for buyer per each 6 month within Quality Guarantee Period, the buyer charge the accommodation and round-trip air tickets of technician, the salary of technicians charge free.

1.10 Installation and debugging remark:

✓ The total quotation have include equipment installation and debugging direction salary and not include international round-trip air tickets、 accommodation and transport cost of technicians in buyer country

✓ The installation & debugging time will be postponed caused by buyer which make equipment can' t installation in time, the buyer should payment salary to technicians \$100 us dollar per technicians per shift for postponed time

II、 Pig abattoir equipment price list:

| No. | Items | Model | Unit | Qty |
|---|---|-------------|------|-----|
| 2.1、 Living pig killing and bleeding and evisceration equipment unit | | | | |
| 1.1 | Living pig stunning box | QE-P105 | Set | 1 |
| 1.2 | Living pig manual stunning device | QE-P106-I | Set | 1 |
| 1.3 | Pig carcass collection table | QE-P212 | Set | 1 |
| 1.4 | Pig carcass scalding and dehairing combined machine | QE-P210 | Set | 1 |
| 1.5 | Pig bleeding vertical lifting machine | QE-P109-II | Set | 1 |
| 1.6 | Pig carcass processing manual convey rail(Dual orbit) | QE-P117-III | M | 12 |
| 1.7 | Dual orbit pulley hook | QE-P507 | Set | 20 |
| 1.8 | Carcass fork | QE-P508 | Set | 20 |
| 1.9 | Carcass band splitting saw | QE-P502-II | Set | 1 |
| 1.10 | Carcass band splitting saw sterilizing | QE-P502-VI | Set | 1 |
| 1.11 | Static track electronic weighing system | QE-P505-II | Set | 1 |
| 1.12 | Viscera cleaning and inspection table | QE-P610 | Set | 1 |
| 1.13 | Boneless table | QE-L102 | Set | 2 |
| 1.14 | Trimming and packaging table | QE-L103 | Set | 1 |
| 1.15 | Boneless knife | QE-L113-I | Pc | 10 |
| 1.16 | Knife sharper | QE-L113-II | Pc | 5 |
| 1.17 | Pig carcass manual cleaning machine | QE-P504-I | Set | 1 |
| 1.18 | Standard trolley | QE-L123 | Set | 2 |
| 1.19 | Hand washing and knife sterilizing device | QE-L202 | Set | 2 |
| 2.2、 Pig abattoir installation material and auxiliary equipment unit | | | | |
| 2.1 | Equipment main support and hanging material | QE-P703 | Ton | 1.5 |
| 2.2 | Equipment installation suspension parts | QE-P704 | Ton | 0.5 |
| 2.3 | Second Hand Shipment Container (40HQ) | QE-P40HQ | Set | 1 |

III、 The pig movable abattoir equipment specification:

2.1、 Living pig killing and bleeding and evisceration equipment unit

1.1 Living pig stunning box-----1Set

Model: QE-P105

Which main used to fix living pig for stunning and killing, main data as following:

- 1)-Work pressure:0.6-0.8Mpa
- 2)-Air consume: 190L/ Time
- 3)-Max capacity: 100 Heads per hour
- 4)-Out size:1700*600*2000mm(L*W*H)
- 5)-Component and material:

- ✓ Pig entrance device
- ✓ Side door opening and closing device
- ✓ Pig collection grid plate
- ✓ Hot galvanized main frame
- ✓ High polymer nylon plate

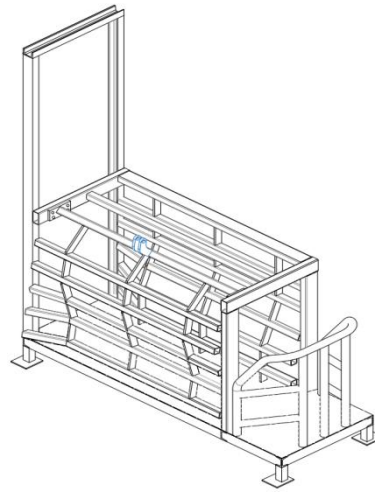

1.2 Living pig manual stunning device-----1Set

Model: QE-P106-I

Which main used for small size abattoir pig stunning or combination with straddle-type conveyor stun machine, main data as following:

- 1)-Electric current: 0.5-1.2A
- 2)-Stunning time: 1~5s
- 3)-Out size: 220X130X340 (LXWXH)
- 4)-Component and material:

- ✓ Stainless steel stunning forceps
- ✓ Stunning generator



1.3 Pig carcass collection table-----1Set

Model: QE-P212

Which main used to collect stunning pig for killing, main data as following:

- 1)-Out size: 3700*800*800mm (L*W*H)
- 2)-Component and material:

- ✓ 38*38*2mm stainless steel square tube
- ✓ 2mm Stainless steel table-board
- ✓ Stainless steel adjusting foot



1.4 Pig carcass scalding and dehairing combined machine-----1Set

Model: QE-P210

Which main used to for small capacity pig abattoir and the scalding machine combine with dehairing machine, main data as following:

- 1)-Rated voltage / phase / frequency: 380v / 3p / 50hz
- 2)-Power:10Kw
- 3)-Working principle: hydraulic
- 4)-Max Capacity:80heads per hour
- 5)-Maximum pig weight:200kg
- 6)-Scalding temperature: 58-62 °C

- ✓ Scalding tank size: 2400*2000*2300mm
- ✓ Dehairing machine size:2700*1700*2080mm

- 7)-Scalding machine component and material:
- ✓ Hot galvanized main frame



- ✓ 80mm polyurethane insulation layer
- ✓ 2mm stainless steel plate shell
- ✓ Stainless steel rotary rake

8)-Dehairing machine component and material:

- ✓ Hot galvanized main frame
- ✓ 2pcs dehairing roller with rubber sheet
- ✓ 2mm stainless steel plate shell
- ✓ Hydraulic pressure station
- ✓ Oil cylinder and hydraulic control system and soft pipe

1.5 Pig bleeding vertical lifting machine-----1Set

Model: QE-P109-II

Which main used to lifting pig carcass from killing table to carcass over head convey rail for bleeding, main data as following:

- 1)-Rated voltage / phase / frequency: 380v / 3p / 50hz
- 2)-Power: 1.5+0.2Kw
- 3)-Hoisting ability: 1000kg
- 4)-Lifting height:6M
- 5)-Lifting speed:8m/min
- 6)-Transport speed:20m/min
- 7)-Component and material:

- ✓ Hot galvanized #16 Transport track
- ✓ Transport device
- ✓ Operating handle
- ✓ Low pressure control switches



Eme-machinerv.com

1.6 Pig carcass processing manual convey rail-----12M

Model: QE-P117-III

Which main used to hang pig carcass for bleeding, evisceration, chilling, boneless and so on, main data as following:

- 1)-Rail Height:2700-3300m
- 2)-Push block distance:600-800mm
- 3)-Component and material:

- ✓ Hot galvanized 10# double channel steel
- ✓ Hot galvanized 10# I-Beam
- ✓ Hot galvanized refined steel casting hanger
- ✓ Connecting bolt
- ✓ 40X40X4mm 304stainless steel dual rail (Dual orbit)

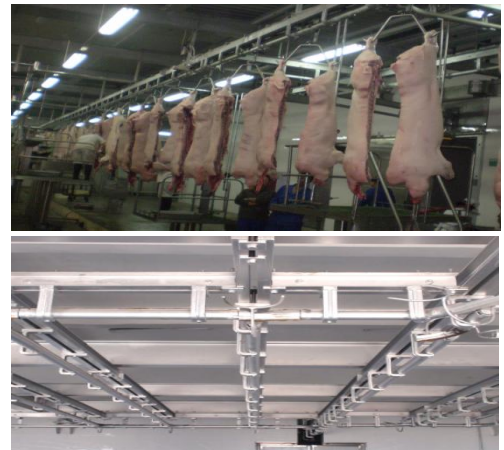

1.7 Dual rail pulley hook-----20Sets

Model: QE-P507

Which main used to hang pig carcass on over head convey rail for bleeding, evisceration, chilling, boneless and so on, main data as following:

- 1)-Max loading:300kg
- 2)-Distance:450mm
- 3)-Component and material:

- ✓ 304 Stainless steel precision casting hanger
- ✓ 2Pcs roller with sealed bearings
- ✓ 304 Stainless steel hooks

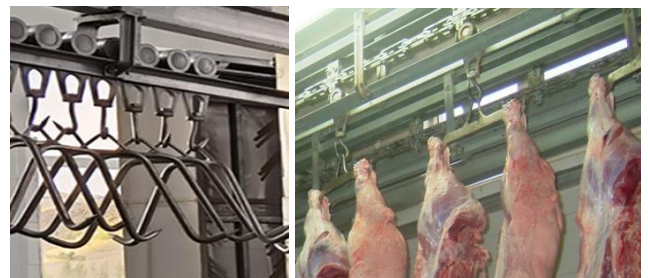

1.8 Carcass fork-----20Sets

Model: QE-P508

Which main used to hang pig carcass and separate pig leg for treatment on over head convey rail for bleeding, evisceration, chilling, boneless and so on, main data as following:

- 1)-Max loading:300kg
- 2)-Distance:350-400mm
- 3)-Component and material:
 - ✓ Stainless steel



1.9 Carcass band splitting saw-----1Set

Model: QE-P502-II (ORIGINAL: CHINA)

Which main used to cut pig carcass into half parts, main data as following:

- 1)-Rated voltage / phase / frequency: 380v / 3p / 50hz
- 2)-Power: 2.2kw
- 3)-Capacity: 400Pig per hour
- 4)-Blade length:2790mm
- 5)-Cutting depth: 360mm
- 6)-Weight:68kg
- 7)-Component and material:
 - ✓ Balance
 - ✓ Transformer
 - ✓ 10pcs saw blade

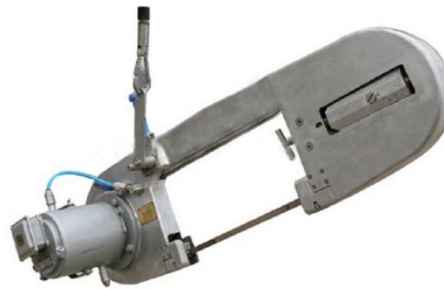

1.10 Carcass band splitting saw sterilizing-----1Set

Model: QE-P502-VI

Which main used for pig carcass band splitting saw sterilizing with hot water, main data as following:

- 1)-Size:800X240X920mm(LXWXH)
- 2)-Material: stainless steel

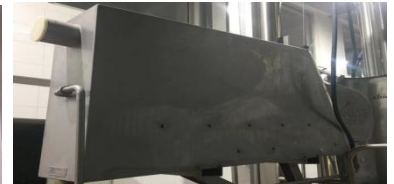

1.11 Static track electronic weighing system-----1Set

Model: QE-P505-II

Which is used to weight pig carcass and installation on over head convey rail, the detail data as following:

- 1)-Weight rail length: 1000 mm
- 2)-Maximum Weight: 300 Kg
- 3)-Differentiate Capacity: 50g
- 4)-Component and material:
 - ✓ Hot galvanized connectors and bolts
 - ✓ 2pcs high precision sensors
 - ✓ Weighing display with printer
 - ✓ LCD digital display
 - ✓ 40*40*4mm independent 304 stainless steel weighing rail (Dual orbit)



1.12 Viscera cleaning and inspection tabl-----1Set

Model: QE-P610

Which main used to collection cattle white viscera from convey machine for cleaning and inspection , the detail data as following:

- 1)-Out size: 2000X900X800mm(LXWXH)
- 2)-Component and material:
 - ✓ 38*38*2mm 304Stainless steel square pipe
 - ✓ 2mm 304Stainless steel plate
 - ✓ Faucet and pipe
 - ✓ 304Stainless steel adjusting foot



1.13 Boneless table-----2Sets

Model: QE-L102

Which main used to for beef、 mutton、 pork、 chicken meat boneless, main data as following:

1)-Out size: 900X600X800mm (LXWXH)

2)-Component and material:

- ✓ 38*38*2mm 304Stainless steel square tube
- ✓ 20mmwhite high polymer nylon board
- ✓ Reservoir at the bottom
- ✓ 304Stainless steel adjusting foot



1.14 Trimming and packaging table-----1Set

Model: QE-L103

Which main used to for beef、 mutton、 pork、 chicken meat trimming and packaging, main data as following:

3)-Out size: 1800X900X800mm (LXWXH)

4)-Component and material:

- ✓ 38*38*2mm 304Stainless steel square tube
- ✓ 1.5mm 304Stainless steel table-board
- ✓ Reservoir at the bottom
- ✓ 304Stainless steel adjusting foot



1.15 Boneless knife-----10Sets

Model: QE-L113-I

Which main used to skinning, trimming and boneless, main data as following:

1)-Length:26.2-31cm

2)-Component and material:

- ✓ 304Stainless steel
- ✓ Food grade plastic handle



1.16 Knife sharper-----5Sets

Model: QE-L113-II

Which main used for knives sharpening, main data as following:

1)-Length:45cm

2)-Component and material:

- ✓ 304Stainless steel
- ✓ Food grade plastic handle



1.17 Half carcass manual washing machine-----1Set

Model: QE-P504-I

Which is used to cleaning pig half carcass by high pressure water, the detail data as following:

1)-Power mode:3-phase electric

2)-Include:15m high pressure explosion-proof steel wire pipe

- ✓ Copper tube high pressure gun
- ✓ High density filter
- ✓ 5m water inlet PVC pipe

3)-Technical parameters:

- ✓ Power: 2.2Kw
- ✓ Rate of flow: 13L/Min
- ✓ Max pressure:18Mpa Power mode:3-phase electric

4)-Include:15m high pressure explosion-proof steel wire pipe

- ✓ Copper tube high pressure gun
- ✓ High density filter



- ✓ 5m water inlet PVC pipe
- 5)-Technical parameters:
- ✓ Power: 2.2Kw
- ✓ Rate of flow: 13L/Min
- ✓ Max pressure:18Mpa

1.18 Standard trolley-----2Sets

Model: QE-L123

Which main used to collect livestock by-product and meat transfer to appoint area for treat or storage, main data as following:

- 1)-Volume:200L
- 2)-Out size: 600X600X600mm(LXWXH)
- 3)-Component and material:
- ✓ 2mm 304Stainless steel tank
- ✓ Bottom fillet structure
- ✓ 4pcs Strongly nylon wheel



1.19 Hand washing and knife sterilizing device-----2Sets

Model: QE-L202-I

Which main used to clean hand and knives sterilizing, main data as following:

- 1)-Heating type:Steam heating
- 2)-Operate type: Foot switch
- 3)-Knives sterilizing water temperature: 82℃
- 4)-Component and material:
- ✓ 2mm stainless steel shell
- ✓ High quality tap
- ✓ Water supply interface and drain valve
- ✓ Rotary thermostat



2.2、 Pig abattoir installation material and auxiliary equipment unit

2.1 Equipment main support and hanging material-----1.5Tons

Model: QE-P703

Which main used for pig abattoir equipment main beam support and hanging, fixed on the upper end of the column by welding, main data as following:

- 1)-Component and material:
- ✓ DN114 Hot galvanized steel column
- ✓ Hot Galvanized Main Steel Beam
- ✓ 25# I-beam,250*118*10
- ✓ 20# I-beam,200*102*9
- ✓ 18# I-beam,180*102*9
- ✓ 16# I-beam,160*102*9

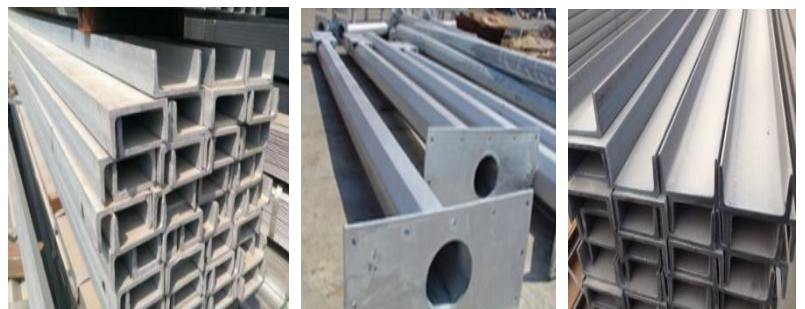

2.2 Equipment main support and hanging material-----0.5Ton

Model: QE-P704

Which main used for pig abattoir equipment main beam support and hanging, fixed on the upper end of the column by welding, main data as following:

- 1)-Component and material:
- ✓ Hot galvanized rigid Connectors
- ✓ Hot galvanized connecting Plate
- ✓ Hot galvanized connecting screw
- ✓ Hot galvanized bolt and nut

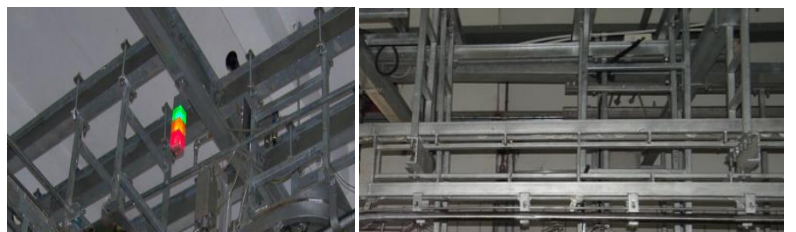

✓ Expansion bolt

2.3 Second Hand Shipment Container (40HQ)-----1Set

Model: QE-P40HQ

Which main used for pig abattoir equipment installation, the detail data as following:

- 1)-Style and Condition: 40HQ and Second Hand (70% new)
- 2)-Out Size: 12192X2438X2896mm (LXWXH)
- 3)-Inner Size: 12000X2350X2700mm (LXWXH)
- 4)-Net Weight: 4200Kg
- 5)-Volume: 76.2M3
- 6)-Door Size: 2340X2580mm (WXH)

